

M-110P Laboratory Model For Continuous High Shear Fluid Processing

Microfluidizer™ Bench-Top Processor Model Is Recommended For:

- Production of stable nano-dispersions and nano-emulsions
- Cell disruption (yeast, *E.coli*, etc.)
- Microencapsulation in polymers, liposomes and oils
- Deagglomeration

The M-110P models have been designed to reliably achieve continuous operating pressures up to 30,000 psi. Microfluidizer™ processors maximize the energy-per-unit fluid volume, resulting in uniform submicron particles.

Available Options

- 400mL stainless steel open reservoir
- 1L stainless steel open reservoir
- 2L stainless steel open reservoir
- 2L pressurized stainless steel reservoir
- 7.6L pressurized stainless steel feed tank
- Manual priming and purging cylinder
- Seal quench system
- Sanitary flush diaphragm pressure transducer with display on touch screen
- Additional interaction chamber
- Auxiliary processing module
- Temperature sensors and displays
- IQOQ documentation and on-site execution
- FAT, SAT, on-site startup and operator training
- Preventative maintenance service
- Extended warranty



Model shown is subject to change depending on options selected.

M-110P "Plug and Play" Laboratory Model for Continuous High Shear Processing

- Achieve processing pressures up to 2068 bar (30,000 psi)
- Produces product flow rate up to 120 ml/min (100 ml/min on 50 Hz model)
- Highest shear rate
- Guaranteed scalability
- Customizable options to suit every application
- Upgrade path to full cGMP model
- 7" HMI colour touch screen control
- CE compliant

Utilizing Microfluidics' fixed geometry interaction chamber technology, and a ceramic (Zirconia) plunger, the M-110P is capable of processing a wide variety of fluids such as oil-in-water emulsions, solids-in-liquid suspensions, and cell disruptions, including the most difficult yeasts and plant cells, in as few as 1-2 passes. What's more, the process is repeatable and is guaranteed to scale up to pilot and/or production volumes.

M-110P Specifications

Description	M-110P
Pressure Range	138 - 2068 bar (2000 - 30,000 psi)
Minimum Sample Size	31mL
Flow Rate* Approximately (With Water)	Up To 120 ml/min - 60 Hz Up To 100 ml/min - 50 Hz
Product Temperature Limit	73°C (165°F)
Power Requirements	60 Hz/120 VAC/20 Amp 60 Hz/230 VAC/10 Amp 50 Hz/220 VAC/12 Amp
Dimensions W x D x H	94cm x 71cm x 56cm (37" x 28" x 22")
Weight	134 kg (295 lbs)
Features	
Interaction Chamber Material	Diamond
Plunger Material	Zirconia Ceramic
Enclosure	Stainless Steel
Drive Method	Electric/Hydraulic
Product Pressure Gage	Mechanical
300 ml Glass Feed Reservoir	Yes
Stainless Steel Feed Reservoirs	Optional

*Based on large chamber.

Standard chambers will reduce flow rate.

Includes Microfluidics standard 1 year warranty.

Microfluidics reserves the right to change specifications without notice.

The M-110P family of machines contains an on-board 1.5KW (2HP) electric-hydraulic drive that powers a single acting intensifier pump. Process pressures may be adjusted from 138-2068 bar (2000-30,000 psi) on the M-110P to produce the desired product results.

As the reciprocating intensifier pump travels through its pressure stroke, it drives the product at constant pressure through the interaction chamber. Within the chamber are unique fixed-geometry micro-channels through which the product stream will accelerate to high velocities. This creates high-shear and impact forces to bring about the desired results as the high velocity product stream impinges on itself and/or on wear-resistant surfaces.

Upon exiting the interaction chamber, the product flows through an external cooling coil which regulates the product to a desired temperature. At this point the product may be recirculated through the system for further processing or sent to the next step in the process.

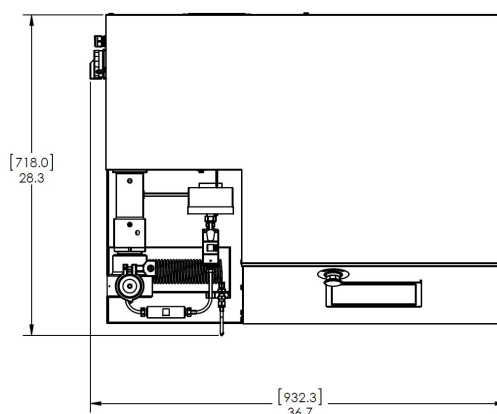

TOP VIEW

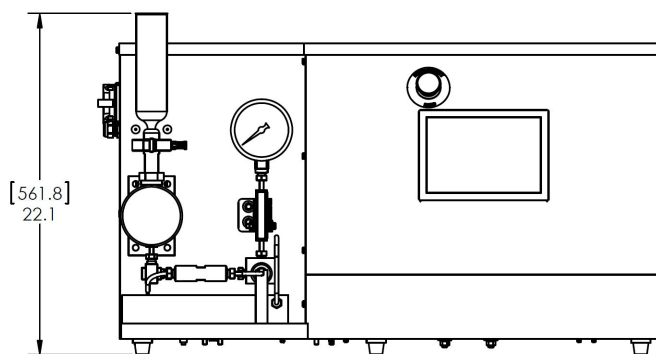

FRONT VIEW



Microfluidics International Corporation
90 Glacier Drive, Suite 1000 • Westwood, MA 02090, USA
Tel: 617-969-5452 • 800-370-5452 • Fax: 617-965-1213
Email: mixinginfo@idexcorp.com • www.microfluidicscorp.com

IDEX Material Processing Technologies
Bramley Drive, Vale Park West, Evesham, Worcestershire, WR11 1JH, UK
Tel: (+44) (0) 1386 769 007 • Fax: (+44) (0) 870 1911116
Email: mixinginfo@idexcorp.com • www.microfluidicscorp.com



© 2010, 2012 by Microfluidics. All rights reserved. 5/16 IH .5K